

Service Bulletin

Subject:

Horizontal Stabiliser Trim Indicator Inspection

Applicability:

GA8 serial numbers GA8-00-004 through GA8-06-100.

Amendments:

Nil (initial issue).

Background:

Situations have arisen where the trim position indicator reaches the end of its travel before the horizontal stabiliser is adjusted to the full leading edge down (i.e. nose up trim) position. When this occurs, further movement of the trim wheel may possibly lead to damage of the trim cable clamp mount, attaching bulkhead and associated hardware.

Compliance:

For all applicable aircraft, inspect the horizontal stabiliser trim indicator clamp mount and the attaching bulkhead (refer to figure 2) in accordance with the inspection procedure detailed in section 1 of the instructions contained in this Service Bulletin at the next 100 hour/annual inspection after 30 April 2006.

Weight and Balance:

Not affected.

Approval:

The technical aspects of this Service Bulletin have been approved under a CASA Authorisation.

Parts:

Item	Part Number	Description	Qty
1	GA8-112011-327	Trim Position Indicator Placard	1

Parts Availability:

Parts can be obtained directly from Gippsland Aeronautics.

Tel.: +61 03 5172 1208

Fax.: +61 03 5172 1237

Email: spares@gippsaero.com

Labour:

Approximately 0.5 hour should be allocated for completing the inspection procedure detailed in this Service Bulletin. A further 1.5 hours should be allocated if modification is required.

Warranty:

Gippsland Aeronautics factory participation is limited to aircraft in warranty at the time of compliance. Gippsland Aeronautics participation is otherwise limited to the supply of parts.

Instructions:

1. Inspection Procedure

- 1.1. Remove round access panel on RHS tail cone skin (refer to figure 1).

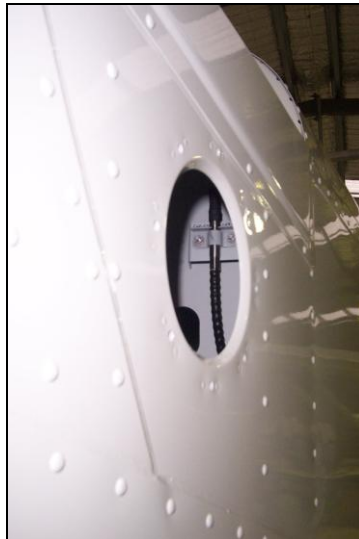

Figure 1

- 1.2. With assistance, starting from an approximately central trim position, trim the horizontal stabiliser to the full leading edge down position and inspect the trim indicator cable to see if the travel limit is being reached before the horizontal stabiliser is in the full leading edge down position. This will be indicated by deflection of the clamp mount, and may also be noticeable to the assistant trimming the horizontal stabiliser by the trim indicator stopping before the trim wheel reaches its limit.
- 1.3. If no deflection of the trim cable mount occurs with the horizontal stabiliser trimmed to the full leading edge down position, record compliance with inspection requirement 1.2 of this Service Bulletin with no defects noted. No further action is necessary.

- 1.4. If deflection of the trim indicator cable mount occurs with the horizontal stabiliser trimmed to the full leading edge down position, an inspection for cracking and other damage of the bulkhead and cable mount is required. To adequately inspect the bulkhead (location indicated in figure 2), remove the large access panel on the lower tail cone skin and inspect the forward face of the bulkhead around the trim indicator cable mount attaching fasteners (refer to figure 3). If defects are found, contact Gippsland Aeronautics. If no defects are found, perform the adjustment to the trim indicator cable in accordance with section 2 of this Service Bulletin (Rod End Adjustment Procedure).

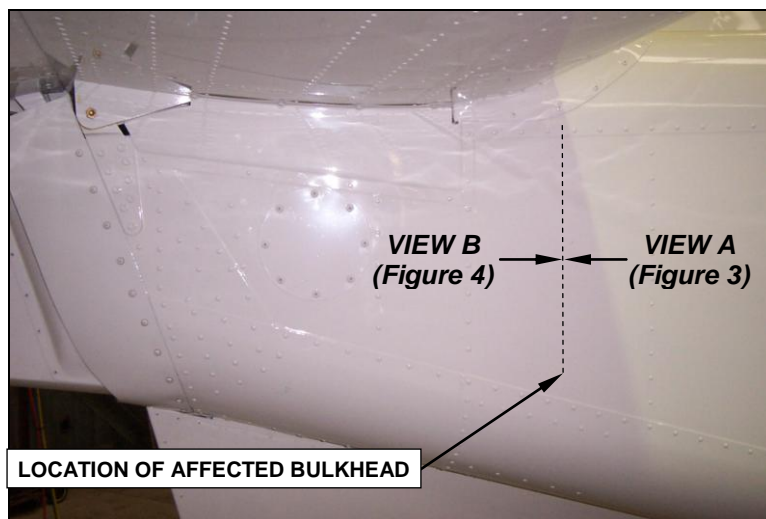

Figure 2

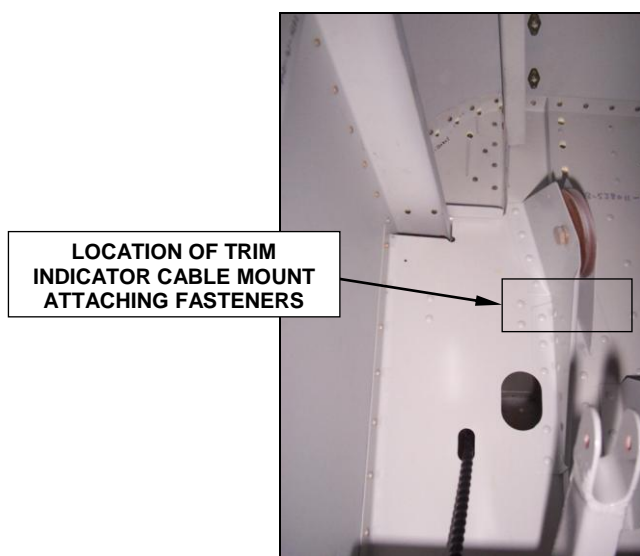

Figure 3 (View A) Looking Aft

2. Rod End Adjustment Procedure

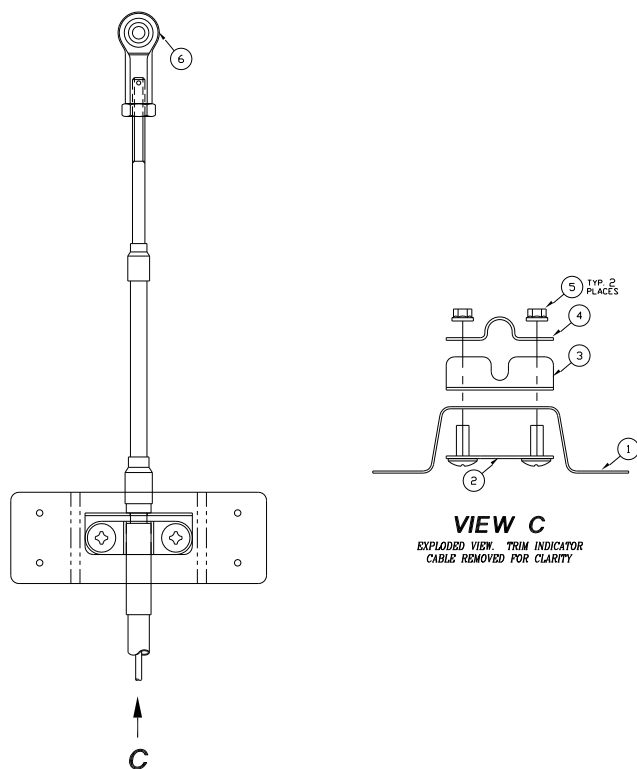

Figure 4 (View B)

- 2.1. Remove fairings and covers as necessary to gain access to the trim indicator cable rod end horizontal stabiliser attachment.
- 2.2. Remove the bolt and washers attaching the rod end (item 6, figure 4) to the horizontal stabiliser front spar.
- 2.3. Loosen the lock nut, screw the rod end down onto the rod as far as possible, and retighten the lock nut.
- 2.4. Reattach the rod end onto the horizontal stabiliser front spar using the original hardware.
- 2.5. Reinstall covers and fairings removed in step 2.1.
- 2.6. Repeat the inspection procedure detailed in section 1 of this Service Bulletin. If no deflection of the trim indicator cable mount occurs with the horizontal stabiliser trimmed to the full leading edge down position, record compliance with inspection requirement 1.2 of this Service Bulletin with no defects noted after adjustment of the rod end, and perform the trim indicator adjustment in accordance with section 4 of this Service Bulletin (Trim Indicator Adjustment Procedure). If deflection of the trim indicator cable mount occurs with the horizontal stabiliser trimmed to the full leading edge down position, perform the modification to the trim indicator cable mount in accordance with section 3 of this Service Bulletin (Modification Procedure).

3. Modification Procedure

NOTE:

Additional access may be obtained by removal of the ventral fin and access panel in the lower tail cone skin (refer to figure 5).



Figure 5

- 3.1. Trim the horizontal stabiliser to an approximately central position.
- 3.2. Unscrew and remove the nuts (figure 4, item 5) attaching the cable clamp components (figure 4, items 3 and 4) to the mount (figure 4, item 1).
- 3.3. Remove the cable clamp components from the screws through the mount.
- 3.4. Remove the screw assembly (figure 4, item 2) from the mount.

CAUTION:

FOR THE FOLLOWING PROCEDURE STEP, CARE MUST BE TAKEN NOT TO DRILL INTO THE BULKHEAD.

- 3.5. Mark and drill 0.192" diameter holes horizontally centred on, with the same spacing, and at a distance of 0.375" down from the existing holes in the mount (refer to figure 6).

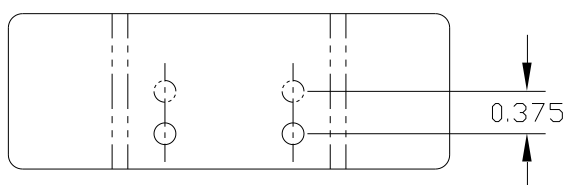

Figure 6

- 3.6. Deburr the new holes in the mount.
- 3.7. Reinstall the screw assembly into the new holes from underneath the mount in accordance with figure 4.
- 3.8. Reinstall the cable clamp components (figure 4, items 3 and 4) with the cable between them over the screws in accordance with figure 4.

- 3.9. Fasten the nuts (figure 4, item 5) on the 10-32 screws and torque in accordance with Chapter 20, Table 1 of the GA8 Service Manual. Figure 7 shows an example of the completed modification of the trim indicator cable clamp mount.

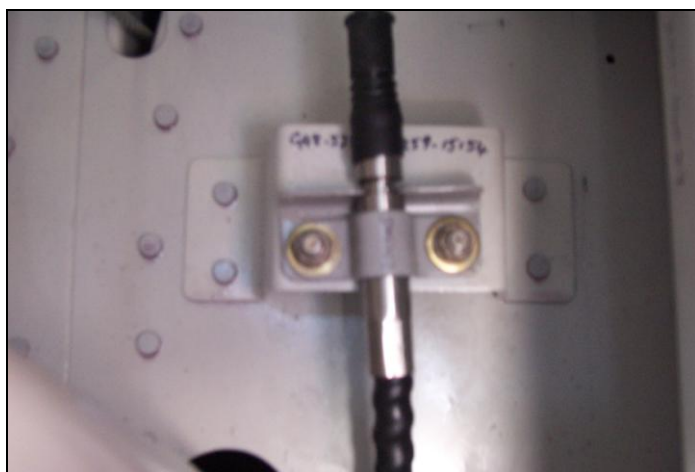

Figure 7

- 3.10. Remove any swarf from inside the tail cone.
- 3.11. Starting from an approximately central trim position, trim the horizontal stabiliser to the full leading edge down position and perform the inspection procedure outlined in section 1 of this Service Bulletin. If deflection of the trim cable mount occurs with the horizontal stabiliser trimmed to the full leading edge down position, contact Gippsland Aeronautics.
- 3.12. Reinstall access panels and the ventral fin as necessary.

4. Trim Indicator Adjustment Procedure

- 4.1. Trim the horizontal stabiliser to the full leading edge up position.
- 4.2. Unscrew and remove the trim indicator guide (refer to figure 8).
- 4.3. Loosen the pointer lock nut and adjust the trim position indicator pointer on the trim indicator cable rod until the middle of the pointer aligns with the nose down mark on the trim position indicator placard (refer to figure 8). Ensure a minimum thread engagement of 4 threads onto the pointer. Tighten the lock nut to secure the location of the trim indicator pointer and reinstall the trim indicator guide.
- 4.4. Alternatively, the trim indicator pointer location may be corrected by locating a new trim position indicator placard P/N GA8-112011-327 with the nose down mark under the trim indicator pointer. Figure 8 shows an example trim position indicator placard installation.

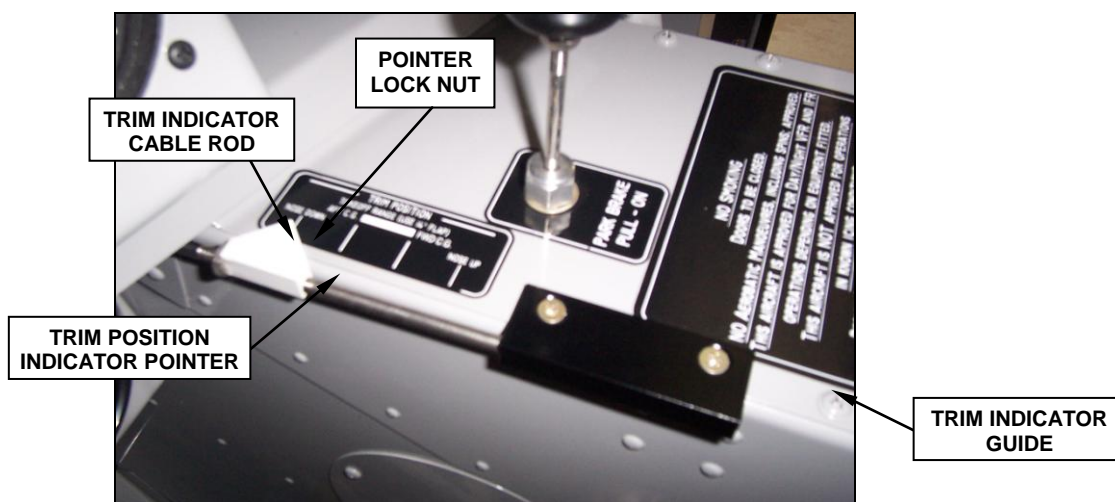

Figure 8

- 4.5. Update the aircraft log book and complete the Compliance Notice.

Documentation:

Update aircraft log book to reflect incorporation of this Service Bulletin.

Compliance Notice:

Complete the Document Compliance Notice and return to Gippsland Aeronautics by fax or mail.

DOCUMENT COMPLIANCE NOTICE



Document: Service Bulletin SB-GA8-2006-35

Aircraft Serial Number: GA8-_____

Service Bulletin SB-GA8-2006-35 Issue 1 has been incorporated in the above aircraft.

Date: _____

Signed

Print Name: _____

Please post or fax this compliance notice to:

Gippsland Aeronautics
Attn: Technical Services
P.O. Box 881
Morwell Victoria 3840
Australia
Fax.: +61 03 5172 1201